

PUMPE 03 RAG-FT Nr. 13.2338.000

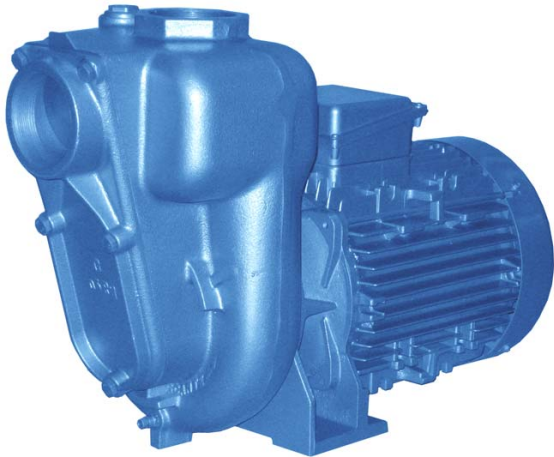

CURVE DI FUNZIONAMENTO E CARATTERISTICHE A 2800 GIRI/MIN
PERFORMANCES CURVES AND SPECIFICATIONS AT 2800 RPM
COURBES ET CARACTÉRISTIQUES DE FONCTIONNEMENT À 2800 TPM



CARATTERISTICHE

Elettropompe autoadescanti a girante aperta.

MATERIALI

- Corpo pompa in ghisa.
- Supporto in ghisa.
- Girante tipo "aperto" in ghisa.
- Albero in Acciaio inossidabile AISI 420.
- Tenuta meccanica "Ceramica-Grafite/NBR" (standard).

MOTORE ELETTRICO

Motore tipo chiuso, a ventilazione forzata.

Servizio continuo.

- Alimentazione trifase: a induzione 400-690v 50Hz, la protezione deve essere prevista dall'utilizzatore con salvamotore opportunamente tarato.

Altre tensioni e frequenze a richiesta.



FEATURES

Self-priming electric pumps, with open impeller.

MATERIALS

- Cast iron body.
- Cast iron flange.
- Cast iron "open type" impeller.
- AISI 420 Stainless Steel shaft.
- "Ceramic-Graphite/NBR rubber" mechanical seal (standard).

ELECTRIC MOTOR

Enclosed type motor with forced ventilation.

Non-stop service.

- Three phase: 400-690v 50Hz induction motor, protection to be carried out by the user: motor protector suitably adjusted.

Other tensions and frequencies on request.



CARACTÉRISTIQUES

Électropompes autoamorçantes avec turbine ouverte.

MATERIAUX

- Corps de pompe en fonte.
- Support en fonte.
- Turbine "type ouverte" en fonte.
- Arbre en acier inoxydable AISI 420.
- Garniture mécanique "Céramique-Graphite/NBR" (standard).

MOTEUR ÉLECTRIQUE

Moteur électrique de type fermé, à ventilation forcée.

Service continu.

- Alimentation triphasée: à induction 400-690v 50Hz, l'utilisateur doit étalonner lui-même le dispositif de protection du moteur.

Autres tensions et fréquences sur demande.

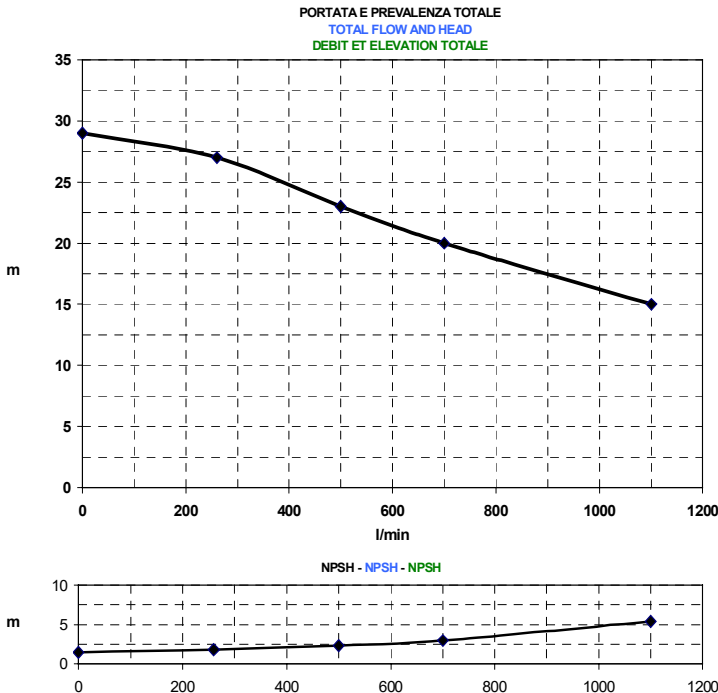

	TIPO POMPA PUMP TYPE TYPE POMPE	CODICE CODE CODE	HP KW	TENSIONE TENSION TENSION		CONDENSATORE CAPACITOR CONDENSATEUR		Q [l/min] ----- H [m] total		
				400 V 50 Hz	Max 12.5 A	MF	VC	1100	700	260
Trifase Three phase Triphasée	03 RA-GF-T	23380.00	7.5 5.5	690 V 50 Hz	Max 7.6 A	-	-	15	20	27

aspirazione 4 m.
Y = 1 kg/dm³.

Max. suction = 7 m.
Total performances obtained at 15°C
with 4 m height suction.
Y = 1 kg/dm³.

Max. en aspiration = 7 m.
Performances totales remarquées à
15°C avec aspiration 4 m.
Y = 1 kg/dm³.

CURVE E CARATTERISTICHE: ISO 9906 GRADO 2 - PERFORMANCES CURVES AND SPECIFICATIONS: ISO 9906 GRADE 2 - COURBES ET CARACTÉRISTIQUES: ISO 9906 GRADE 2

DATI SOGGETTI A MODIFICHE SENZA PREAVVISO - DATA SUBJECT TO CHANGE WITHOUT PRIOR NOTICE - TOUS LES DONNÉES SONT SUJETES À MODIFICATIONS SANS PREAVIS

AVAG-PUMPEN Import-Export GmbH Leiberger Straße 27 | 33181 Bad Wünnenberg
Telefon 0 29 53 - 98 06 0 | info@avag-pumpen.de | www.avag-pumpen.de

PUMPE 03 RAG-FT Nr. 13.2338.000

DIMENSIONI DI INGOMBRO IN MM. E PESI - DIMENSIONS IN MM. AND WEIGHTS - DIMENSIONS EN MM. ET POIDS

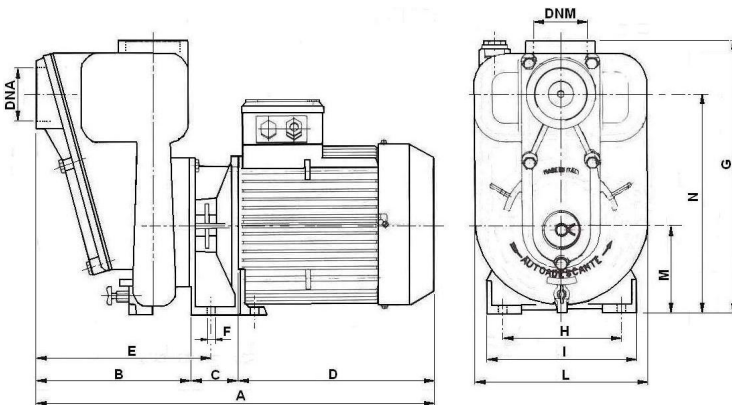

DNM	DNA	A	B	C	D	E	F
3" GAS	3" GAS	651	240	81	330	273	Ø 13
G	H	I	L	M	N	Peso Weight Poids	
435	190	240	274	140	350	Kg 75	

SEZIONE POMPA E PARTI DI RICAMBIO - PUMP CROSS SECTION AND SPARE PARTS LIST - SECTION DE LA POMPE AVEC LES PIÈCES DÉTACHÉES

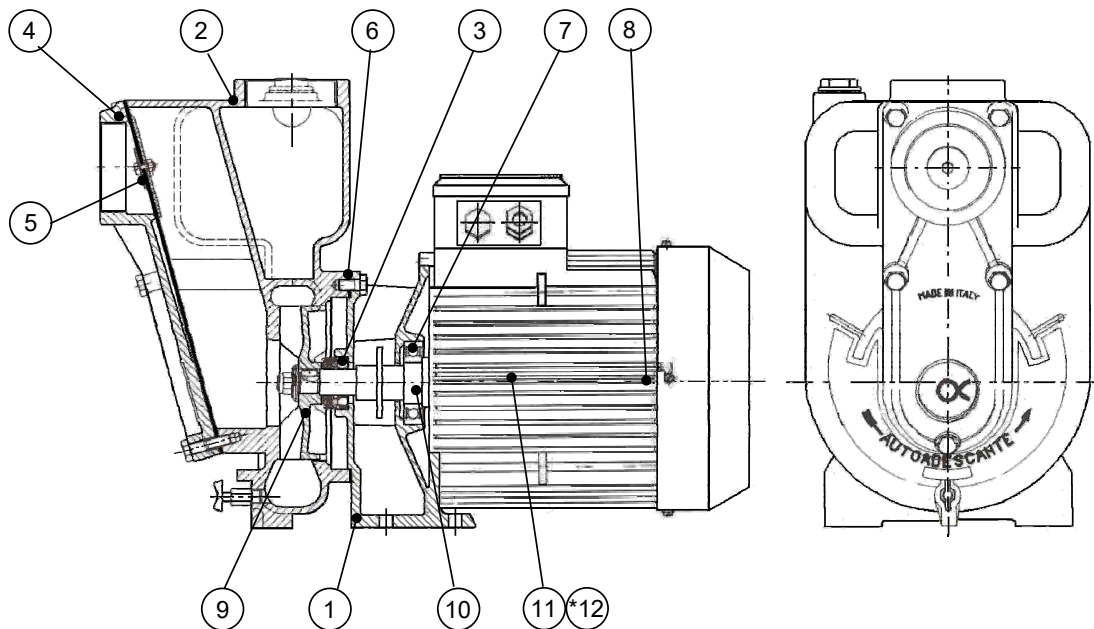

POS. N.	DENOMINAZIONE - DESCRIPTION - DENOMINATION			03 RA-GF -T 23380.00
1	Flangia	Flange	Flasque	02812.01
2	Corpo	Casing	Corps	23000.02
3	Tenuta meccanica	Mechanical seal	Garniture mécanique	01500.22
4	Coperchio	Cover	Couvercle	23000.04
5	Guarnizione coperchio	Cover gasket	Joint du couvercle	23000.05
6	Guarnizione flangia	Flange gasket	Joint de la flasque	01500.06
7	Cuscinetto anteriore	Front bearing	Coussinet antérieur	-
8	Cuscinetto posteriore	Back bearing	Coussinet postérieur	-
9	Girante	Impeller	Turbine	23334.99
10	Albero e rotore	Shaft and rotor	Arbre et rotor	-
11	Motore elettrico	Electric motor	Moteur électrique	H575D.00
* 12	Statore avvolto con carcassa	Winded stator with casing	Stator bobiné avec carcasse	* - * -

DATI SOGGETTI A MODIFICHE SENZA PREAVVISO - DATA SUBJECT TO CHANGE WITHOUT PRIOR NOTICE - TOUS LES DONNÉES SONT SUJETES À MODIFICATIONS SANS PREAVIS

AVAG-PUMPEN Import-Export GmbH Leiberger Straße 27 | 33181 Bad Wünnenberg
 Telefon 0 29 53 - 98 06 0 | info@avag-pumpen.de | www.avag-pumpen.de